

TIPS AND TRICKS

FOR LEKKIE PF30 ECCENTRIC ADAPTER

ADAPTS FRAMES WITH 46MM PF30 BOTTOM BRACKETS TO ALLOW FITMENT OF BAFANG BBS01, BBS02, BBSHD MID DRIVE MOTORS.

INCLUDES

- A** 1X ADAPTER SLEEVE
- B** 1X MOTOR PLATE
- C** 2X MOTOR PLATE SCREWS
- D** 2X EXPANDER SCREWS

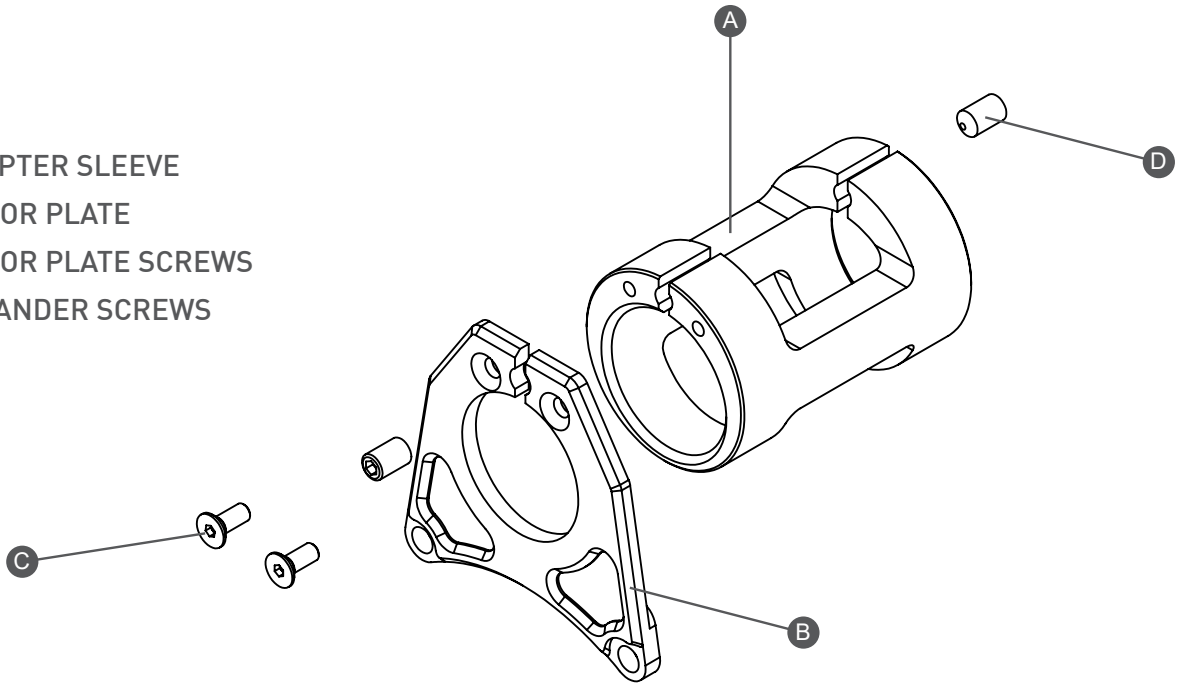

TOOLS REQUIRED

- 2.5mm hex key
- 3mm hex key
- 5mm hex key
- 4 notch Bafang socket
- 16 notch Bafang Socket
- All purpose lithium grease

When installing the Lekkie PF30 Adapter you will require some tools and some hands on experience with your motor. If you do not the have required tools, confidence or skills to install this take your motor to your local bike shop or engineering shop and they should be able to help you out.

INSTALL TIPS

Here are some tips to keep in mind while completing the install.

- To keep everything running smooth end easy to maintain make sure you grease all metal to metal surfaces.
- Always grease the axle taper before install cranks.

FRAME GEOMETRY

This adapter will only work with certain frame geometries. If your frame does not fit these specifications the adapter or motor will not fit your frame.

Ideal BB Diameter

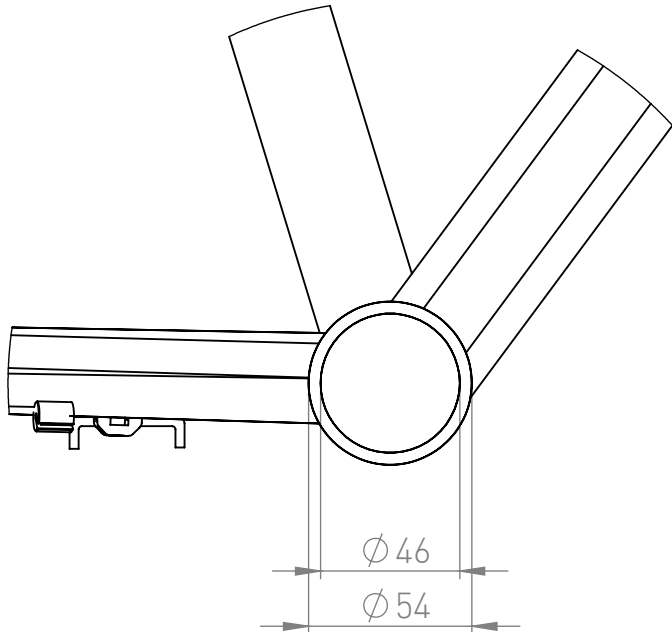

Ideal BB widths - note if 73mm BB you will need a Lekkie 5mm Motorspacer.

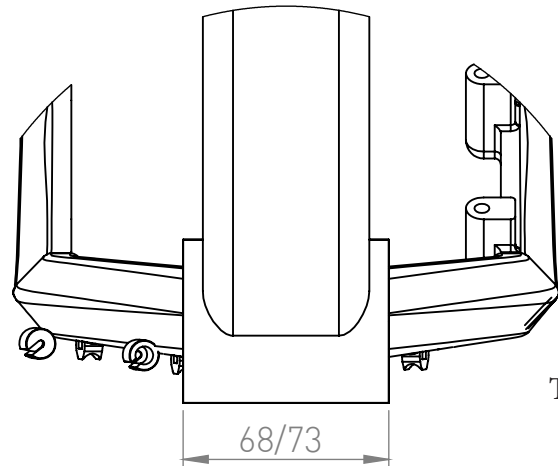

TT02 Steering

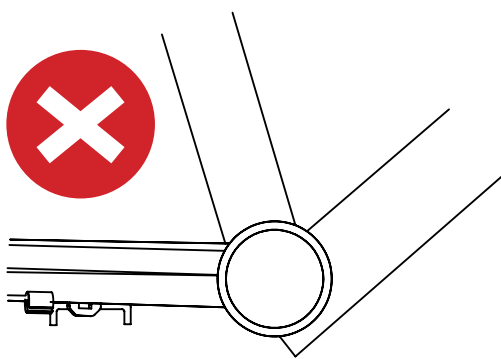

Protruding tubes, Chain guide mounts or welds may get in the way of the motor.

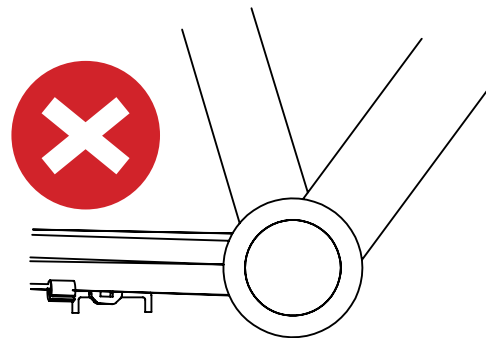

Carbon frames often have a lot of reinforcing under the BB of the frame the motor can not fit

INSTALL

Install is reasonably straight forward, just a few extra steps from a standard conversion. Do not force any parts and if you are unsure, stop the assembly and contact us.

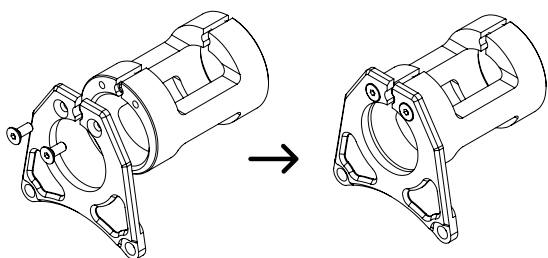

1. Assemble the Motor Plate to the Adapter. Use a drop of Loctite onto the Motor Plate Screws then tighten to 3Nm.

Note: make sure Exapander Screws are wound out.

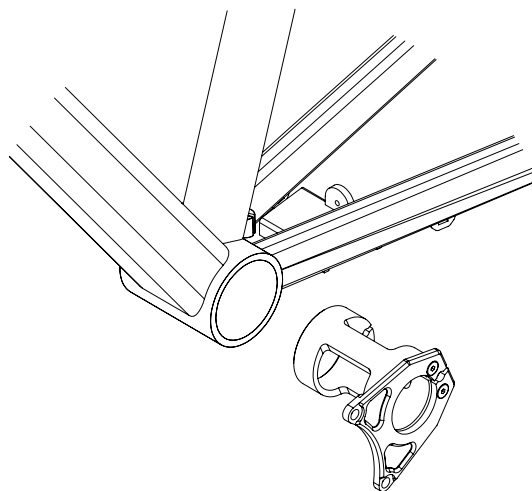

2. Slide into frame from the left side and push hard against the frame. It should be rotatable.

Note: if 73mm BB frame there will be a 5mm gap on the right side frame edge of frame to adapter. This is fine, you DO NOT need to modify your frame.

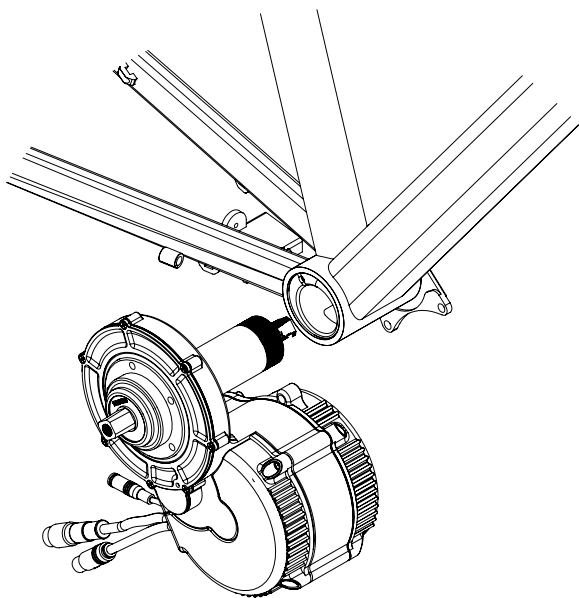

3. Slide your motor in from the right side. install the M6 bolts you would usually use for the stock plate and screw the motor to the Motor Plate.

Note: you may require a 5mm Motorspacer to take up the gap.

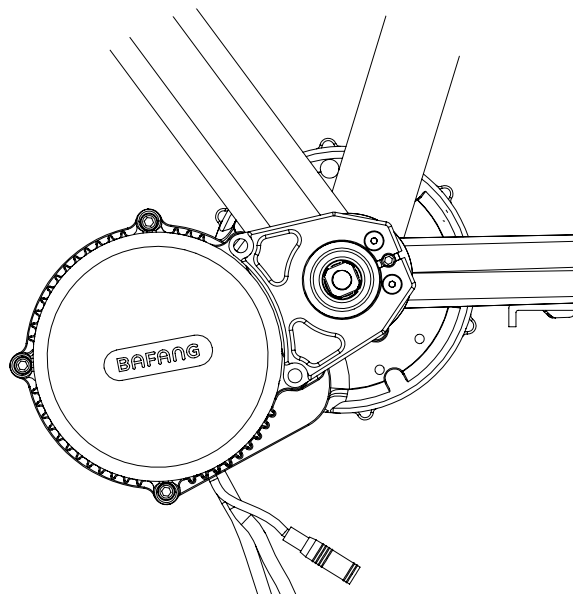

4. Rotate the motor up until it stops on the frame, hold and tighten the left Exapander Screw. This will expand the adapter.

INSTALL

Install is reasonably straight forward, just a few extra steps from a standard conversion. Do not force any parts and if you are unsure, stop the assembly and contact us.

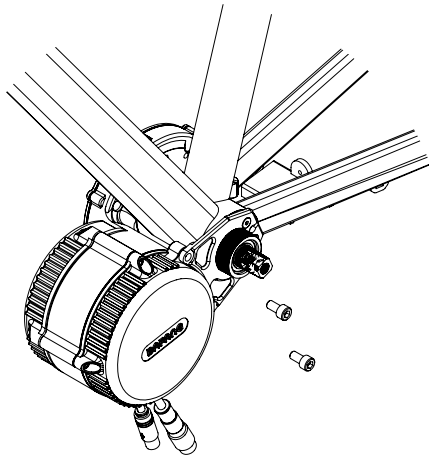

5. Unscrew to the motor from the Motor Plate and slide the motor out.

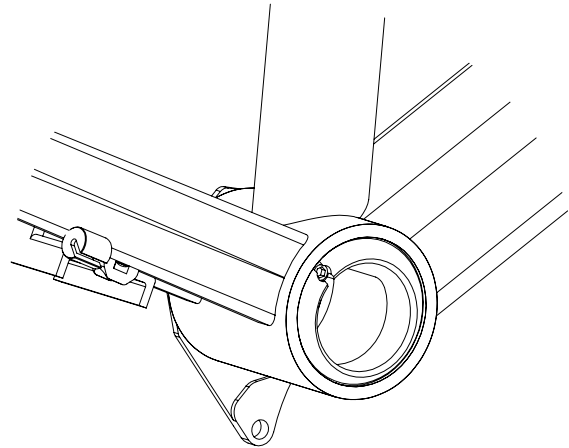

6. Tighten the right Expander Screw.
Note: Make sure not to tie up too much that the screw goes all the way through.

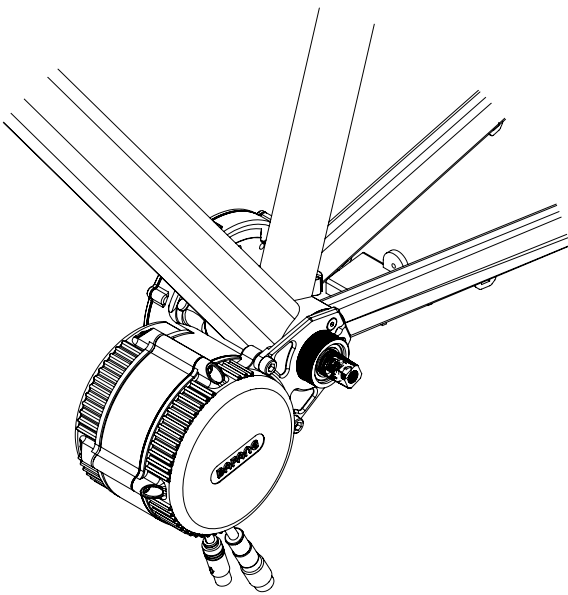

7. Slide your motor in from the right side and attach the motor back on to the Motor Plate using the M6 screws. Tighten to 9Nm.
Note: you may require a 5mm Motorspacer to take up the gap.

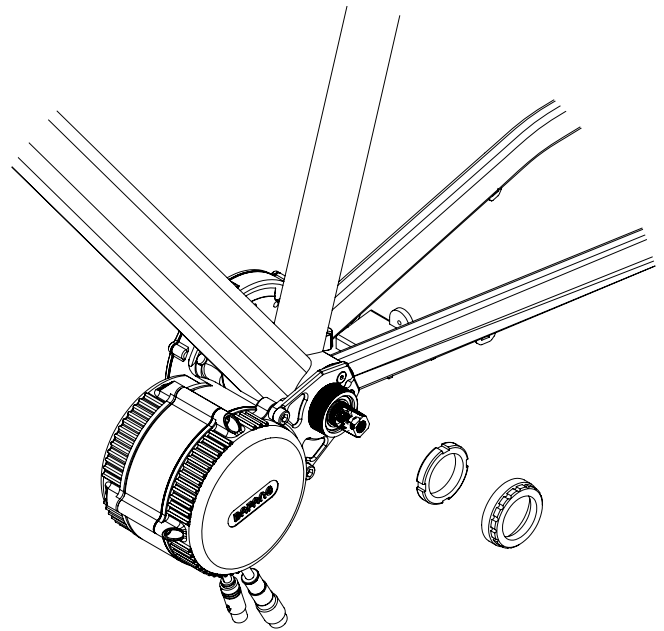

8. Install the stock Bafang lock rings and carry on with your build like a normal conversion.

DIMENSIONS

Here are the basic dimensions of the Adapter. Note the image is just an illustration to explain the drawing.

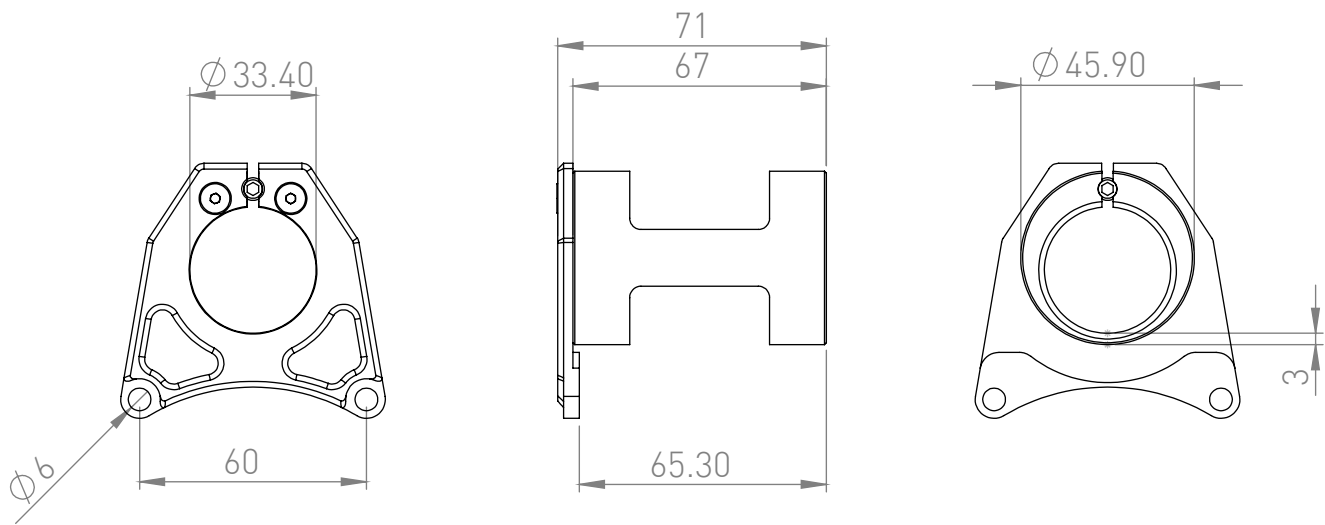

WARRANTY

At Lekkie we don't accept anything but the best workmanship and quality. If a part has slipped through our QC system and made it to your hands let us know and we will put it right.

If one of our products fails we want to know so we can make our products better. If you destroy a lekkie product in extreme use tell us. We can learn from this and sell you something so suit your needs.

If you are in anyway unhappy with your Lekkie product get in touch so we can put it right.